



---

# Operator's Manual

---

## Model P20-5010/P20-9010 Series

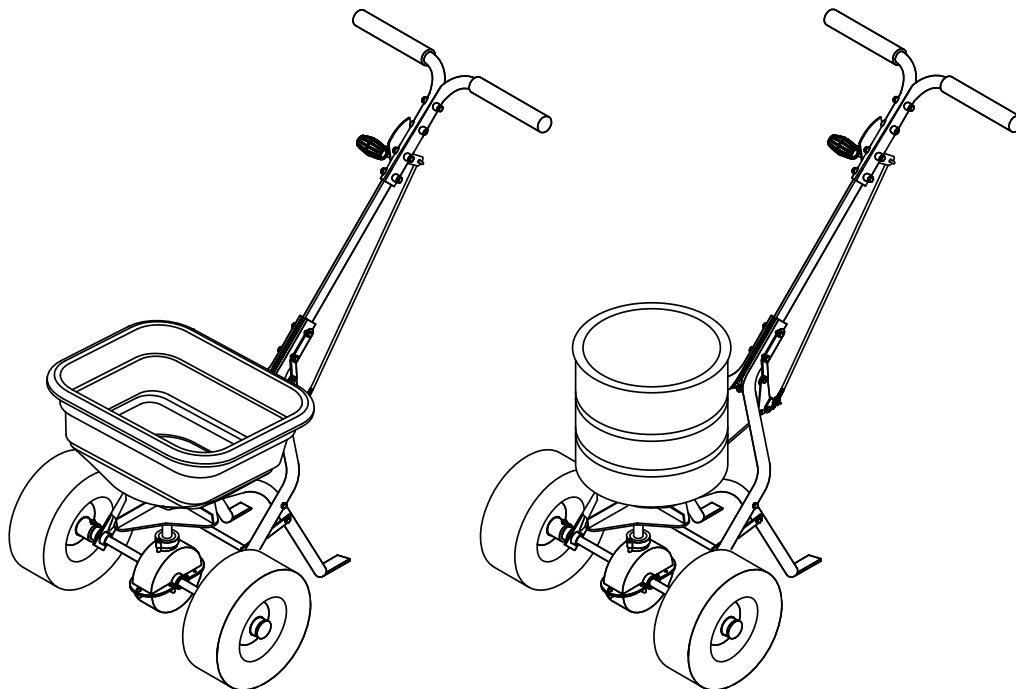

**▲IMPORTANT** This manual contains information for the safety of persons and property. Read it carefully before assembly and operation of the equipment!

**Spyker Spreaders**  
**Contact Us at 800.972.6130**

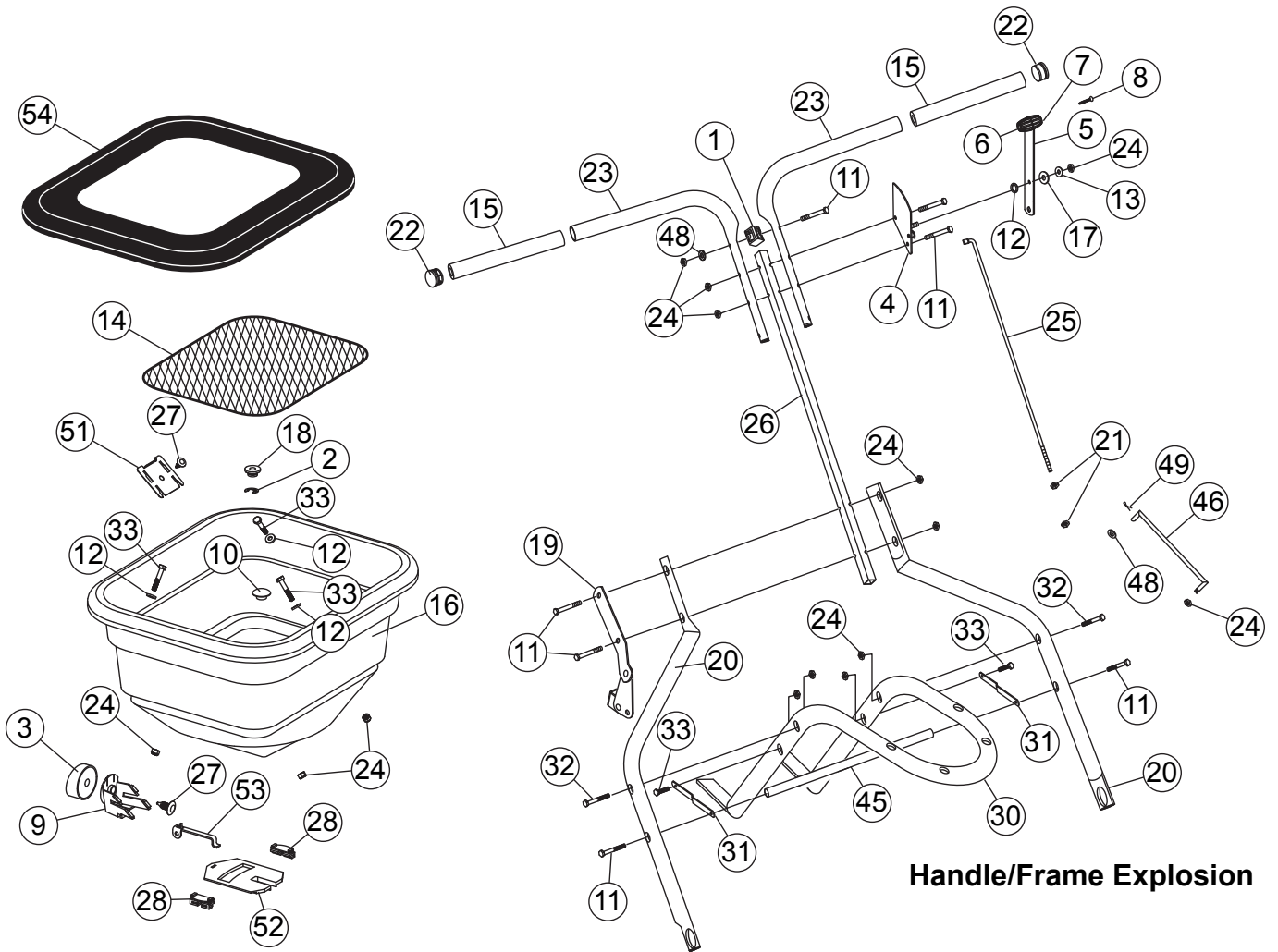

**Handle/Frame Explosion**

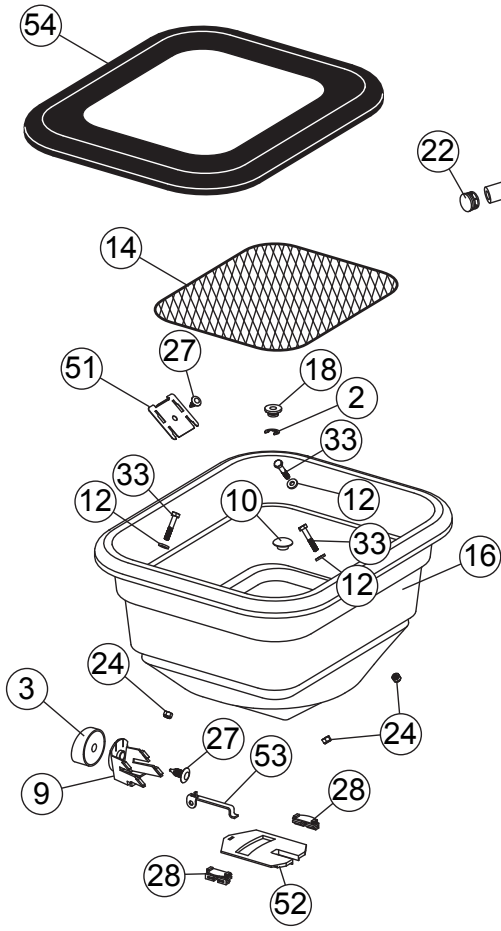

**Hopper Explosion**

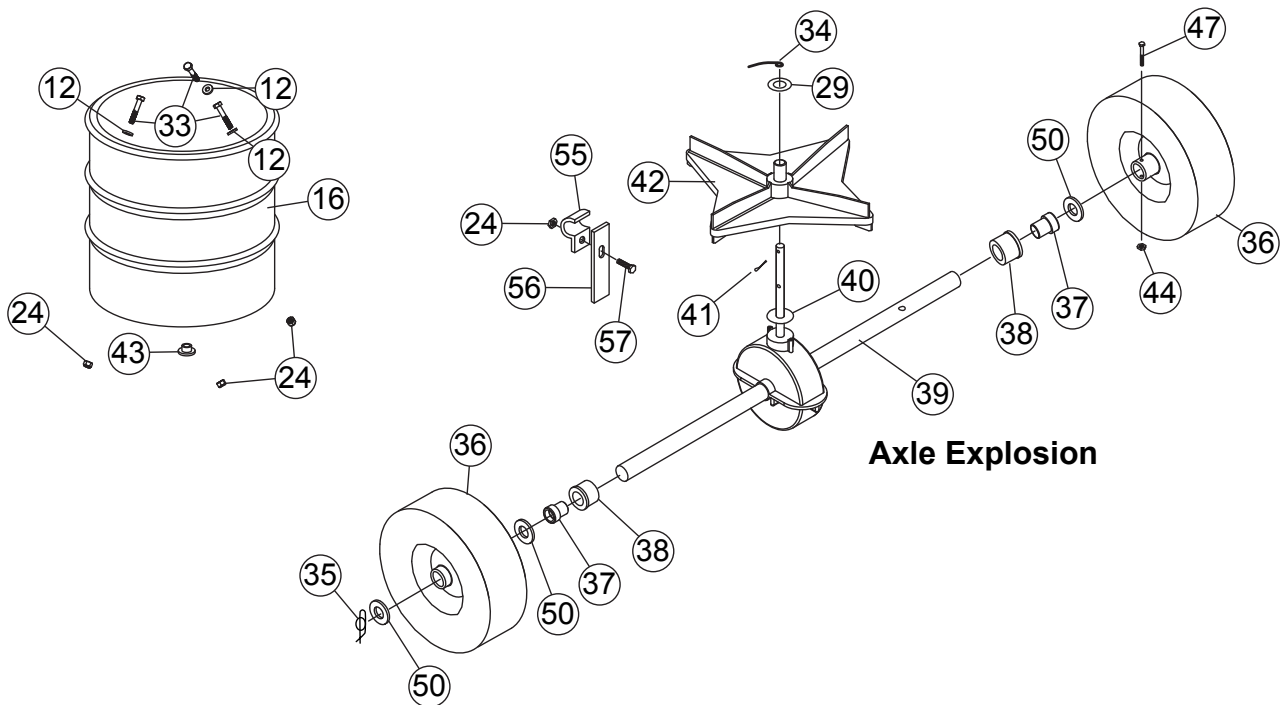

**Axle Explosion**

## PART LIST

Item	Part #	Qty	Description
1	1007081	1	Handle spacer
2	F-577	1	E-Ring
3	1000213	1	Dial
4	1008028	1	Gauge Plate
5	1008156	1	Adjust handle
6	1007086	1	Adjust handle knob side 1
7	1007087	1	Adjust handle knob side 2
8	1007088	1	Screw, M4 x 18 SS
9	1001587	1	Dial Mount Plastic Hopper
	1000211	1	Dial Mount Metal Hopper
10	1001590	1	Diffuser Plug (Plastic Hopper)
11	1007091	7	Bolt, M6 x 45 SS
12	1007092	4	Nylon washer
13	1007093	1	Flat washer, M6, big SS
14	1008022	1	Screen For Plastic Hopper
15	1007095	2	Handle cover
16	1007892	1	Plastic Hopper Black
	1000204	1	Metal Hopper
17	1008207	1	Lockwasher, M6 SS
18	F-574	1	Hopper bushing
19	1008196	1	Pivot and bracket assembly
20	1007100	2	Wheel frame tube
21	1008206	2	Nut, Nylon Lock M8 SS
22	1007102	2	End cover
23	1007103	2	Upper handle
24	1007104	14	Lock nut, M6 SS
25	1008013	1	Control rod A
26	1007106	1	Handle shaft
27	1000215	2	Pine Tree Clip
28	1001588	2	Rate Gate Guide Plastic Hopper
	1000202	2	Rate Gate Guide Metal Hopper
29	1000198	1	Felt Washer
30	1008011	1	Frame

Item	Part #	Qty	Description
31	1007111	2	Frame brace
32	1007112	2	Bolt, M6 x 60 SS
33	1007113	5	Bolt, M6 x 35 SS
34	1000223	1	Agitator
35	1005414	1	Rue Ring Locking Pin
36	1008027	2	Pneumatic wheel
37	1007117	2	Axle bushing
38	1007118	2	Axle bearing
39	1008010	1	Gearbox & axle assembly
40	1007120	1	Washer
41	1008031	1	Cotter Pin
42	1008209	1	Impeller
43	1000203	1	Bearing, Metal Hopper
44	1007124	1	Hex locknut, M5 SS
45	1007125	1	Cross brace
46	1008014	1	Adjust connect rod, B
47	1008208	1	Hex bolt, M5 x 40 SS
48	1007128	2	Flat washer, M6 SS
49	1020282	1	Cotter Pin, Small
50	1007531	3	Nylon Washer
51	1005993	1	Dial Mount Retainer (Plastic Hopper)
52	1000210	1	Rate Gate
53	1000687-01	1	Rate Gate Link
54	1008110	1	Cover, Square Hopper
55	1008257	1	Bracket, Frame Clamp
56	1008258	1	Bar, Frame Clamp
57	1008276	1	Hex Bolt, M6 x 20 SS

## ASSEMBLY

1. Remove two M6 locknuts and M6 x 45mm long bolts to remove pivot and bracket assembly from wheel frame tubes. Set bolts and nuts to the side. You will re-install them in Step 2.

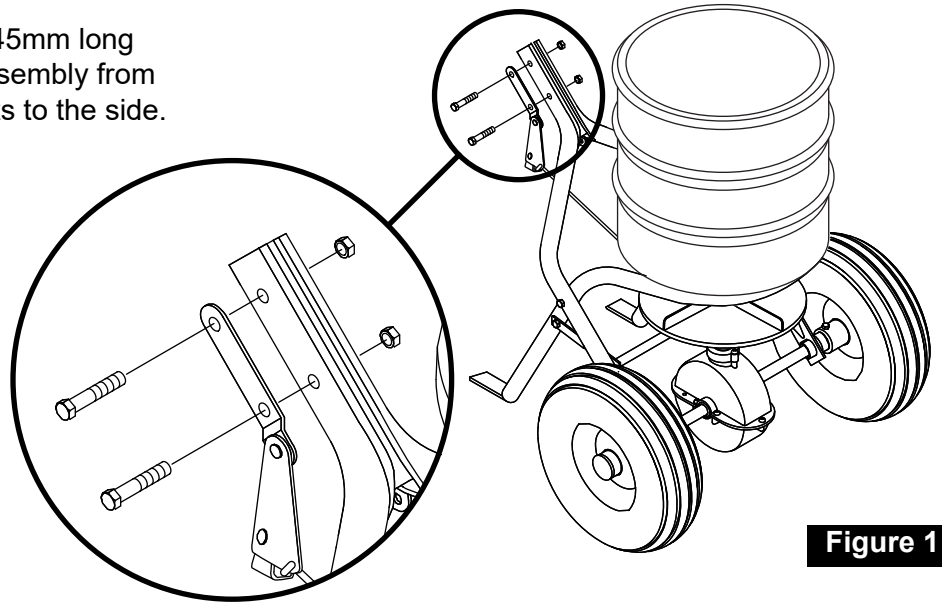

Figure 1

2. Insert arm assembly between frame tubes. Re-install pivot and bracket assembly through wheel frame tubes and arm assembly with two M6 x 45mm bolts and M6 locknuts removed in Step 1.

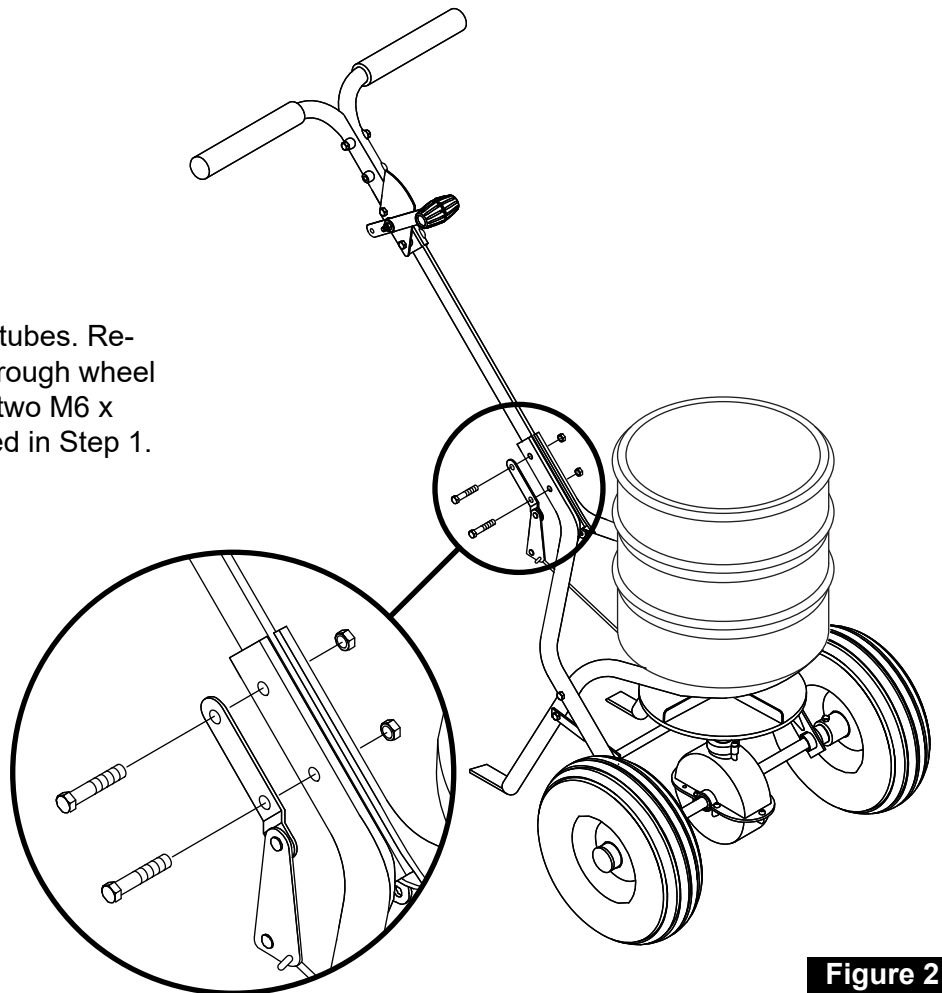
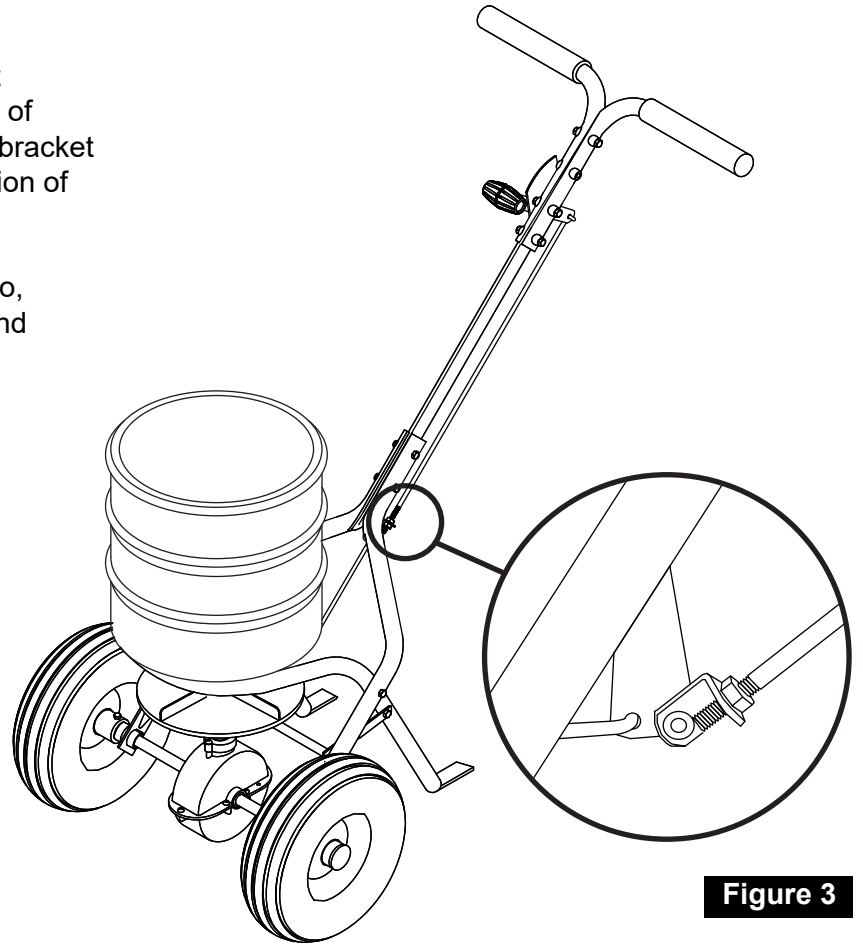

Figure 2

## ASSEMBLY

3. Rotate control rod and insert into adjustment handle, Figure 3. Remove one nut from end of control rod. Insert control rod into pivot and bracket assembly as shown, Figure 3. Note orientation of bracket. Install second nut finger tight only.

Ensure rate gate opens and closes fully. If so, hold the upper control rod nut with wrench and tighten the bottom nut only.



**Figure 3**

4. Tighten nuts and bolts on both sides of spreader at locations shown.

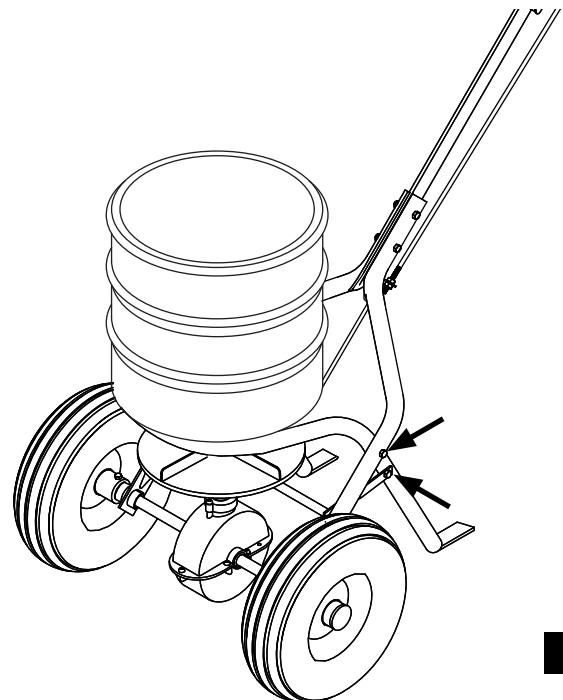

**Figure 4**

## **READ BEFORE USING**

### **OPERATE SAFELY**

Keep bystanders away when you operate this machine.

Use this machine for intended purpose only.

Do not let children or an untrained person operate machine.

Keep all parts in good condition and properly installed. Fix damaged parts immediately. Replace worn or broken parts.

Do not modify the machine or safety devices. Unauthorized modifications to the machine may impair its function and safety, and void the warranty.

Do not let anyone sit or ride on equipment during operation. Keep riders off attachment.

Wear substantial footwear and long trousers. Do not operate the equipment when barefoot or wearing open sandals.

Do not wear loose fitting clothing that can get caught in moving parts.

Always wear eye protection when operating the equipment.

Stay alert for holes in the terrain and other hidden hazards.

Watch out for traffic when crossing or near roadways.

Before you operate any feature of this machine, observe your surroundings and look for bystanders.

Always wash hands after contact with fertilizers and pesticides.

Keep all nuts, bolts and screws tight to be sure the equipment is in safe working condition.

## READ BEFORE USING

### Become Familiar With The Operation Of The Spreader Before You Put Material In The Hopper

- Practice walking with the spreader, opening and closing the rate gate at the appropriate times.
- Travel at a constant speed and operate the spreader lever position. Remember: Open the rate gate after the spreader is in motion at operating speed (about 3 mph, or at a brisk walking pace).
- Close the rate gate while spreader is still at operational speed.

#### Dial Setting Information

The RATE DIAL has 9 numbers with 10 stops between each number. This allows for accurate control of the spreading rate. The dial is set with only a turn, it will automatically lock into the set position. LINE UP THE DIAL NUMBER WITH THE DIAL INDICATOR.

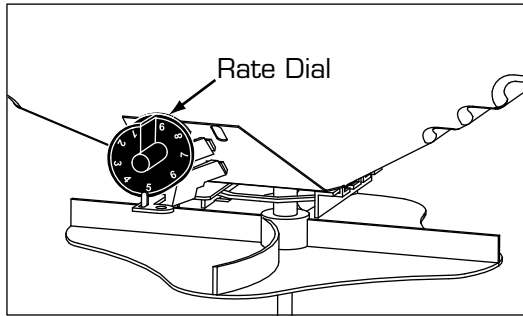

- The spread width ranges from 4 - 12 ft. wide depending on the volume/density, particle size of the material, and rate of travel.
- The spread thins or feathers at the outer edges, eliminating sharp, "Edge Of Spread" lines which cause stripes and streaks. Extra coverage can be given under trees and other heavy feeding areas without showing "Edge Of Spread" lines.
- Gaps and double overlaps are less likely. Small errors in travel are forgiven and do not show.

**WARNING:** When spreading products containing herbicides, exercise extreme caution with respect to careless spreading and to wind-drift.

#### Contact Of Some Products On Some Plants Can Be Fatal

If a dial setting is not found, use the size and weight comparison table found in this manual. Determine a dial setting on the low side. If the setting proves to be too low, cover the area more than one time. A higher setting can be used when a proven dial setting is established.

**Remember:** Published dial settings are approximate only. The operation of the spreader, the condition of the material (damp or dry or over-pulverized) and weather conditions, are all contributing factors. For these reasons, it is often a good idea to spread the area 2 times - or one-half rate - in cross directions (SEE INFORMATION ON ONE-HALF RATE DIAL SETTINGS). One-half rate dial settings are highly recommended under damp and humid conditions.

#### Rotary Agitator

Use the rotary agitator only if needed. Free-flowing, lump-free materials will not require the agitator. The rotary agitator is easily installed or removed. Note the clockwise rotation and sweep. Place felt washer around spinner shaft before inserting agitator.

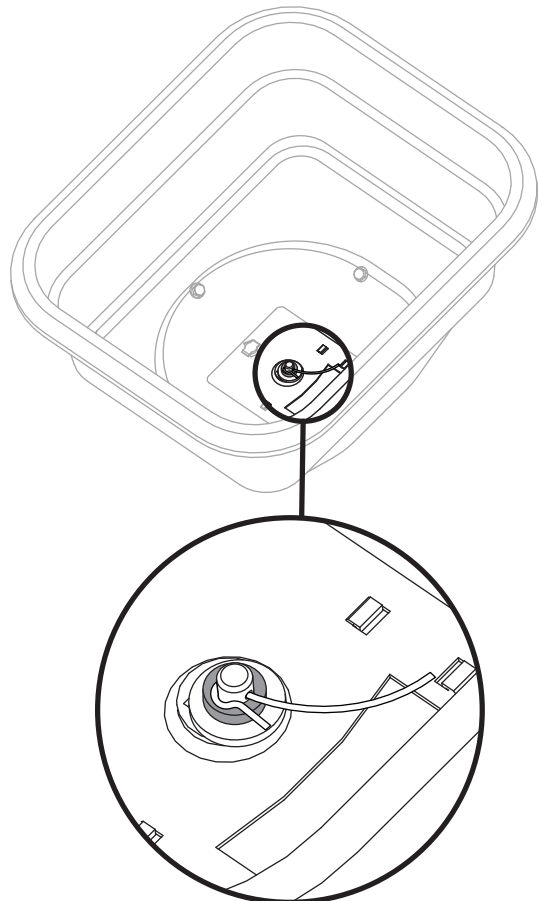

## READ BEFORE USING

### Now You Are Ready To Put Material In The Hopper

**WARNING:** Avoid Injury! Chemicals can be dangerous. Avoid injury to operators or bystanders.

- Make sure the rate gate is in the closed position.
- Read chemical container label for handling instructions. A Material Safety Data Sheet (MSDS) should be supplied by the chemical dealer and provides proper safety information.
- Wear proper clothing and safety equipment while handling or applying chemicals.
- Prohibit all smoking, drinking & eating around chemicals.
- When spreading products containing herbicides, exercise extreme caution with respect to careless spreading and to wind-drift. Contact Of Some Products On Some Plants Can Be Fatal.
- Fill the spreader on a flat, level surface only. Fill on sidewalk, driveway, cardboard, etc. to avoid material loss.
- When filling hopper with material, always use screen to help break up clumps.

### Now You Are Ready To Spread

- Keep spinner blade clean. Excess material build-up can cause an uneven spread pattern.
- Keep the impeller level when spreading.
- DO NOT overload. Maximum capacity is 50 lbs.
- DO NOT use on windy days.
- Spread header strips at the ends of the area OPPOSITE of the direction of spreading. This will provide a "turn-around" area, an area to re-align the spreader for the return spread.
- Example shown is for 6 ft. wide spread. Make the first spread pass at one-half the spread width from the edge of the spreading area or in this case, approximately 3 feet (or one big step).
- Additional spreading passes will be at the full spread width or approximately 6 ft. apart.
- TAKE A SIGHTING AT THE FAR END. Keep your eye on the sighting as you spread. You will not need to wonder where you are or where you have been. Continue until spreading is completed.
- Left over fertilizer can be spread under trees and other high feeding areas without showing "edge of spread" lines.

**Tip:** When not spreading, and if pushing the spreader some distance, tip the spreader so only the idle wheel is on the ground.

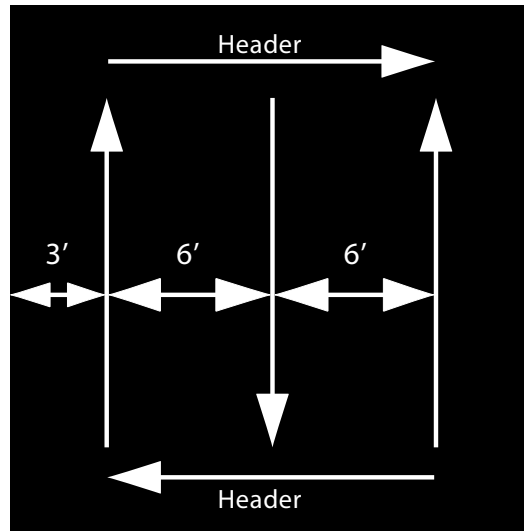

### Cleaning The Spreader Is Part Of The Spreading Job

Clean and oil spreader immediately after each use.

**METHOD #1** - Wipe spreader thoroughly with an oily cloth. Oil all bearings and bearing areas.

**METHOD #2** - Wash, rinse, and dry the spreader. Note: Drying takes time. Moisture trapped in bearing areas is slow to go. Immediately after drying - oil all bearings and moving parts. Make certain all operations are thorough.

**NOTE:** *Good "Dry Cleaning" is preferable to poor "Wet Cleaning."*

- It is virtually impossible to have rust and corrosion on a clean, dry, oiled surface.
- Again - just before using - oil all bearings and moving parts.
- In storage, ideally the spreader should be hung by the handle. In any case, do not pile weight on the spreader, as excess weight over a period of time can distort the tires.





### Oil Bearings And All Moving Parts

Make sure the spreader is running freely!

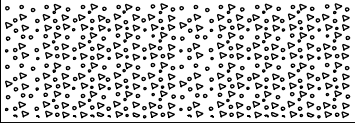
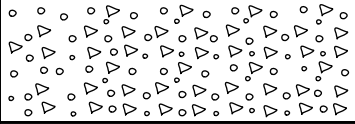
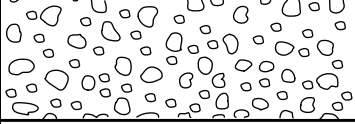

## TROUBLESHOOTING

<b>Spreader does not sit flat</b>	The "feet" or the flattened portion of the spreader hopper support tubes are not bent equally.	Using a hammer or pliers, bend the feet to be equal with each other.
<b>Deflector shut-off is binding and will not open/close properly</b>	Shut off plate is jammed with debris.	Thoroughly wash out hopper and shut off plates with water. Ensure debris is not stuck between shut off plate and rate gate plate.

<b>NOTE: Dial Settings Are Approximate Only !</b>			<b>Dial Settings</b>	<b>Dial Settings</b>
<b>Product</b>	<b>Particle Size</b>	<b>Lbs. per 1000 sq. ft.</b>	<b>Full Rate Once Over</b> ↑ ↓	<b>Half Rate Twice Over</b> ← →
Fine Pellets		1	3.6	3.1
		2	4.0	3.5
		3	4.2	3.7
Mixed Fine Pellets		2	3.7	3.2
		4	4.7	4.1
		6	5.2	4.5
Small Pellets		2	3	2.2
		4	4.2	3.7
		6	4.5	4
Nitrogen Pellets Medium Size		1	3.5	3
		2	4.2	3.7
		3	4.7	4
Medium Pellets And Granuals		2	3.5	3
		4	4.2	3.8
		6	5.2	4.5
Large Heavy Pellets		2	3.8	3.3
		4	4.9	4.1
		6	5.9	4.9

<b>GRASS SEED SPREADING CHART</b>					
<b>Product</b>	<b>Bag Weight</b>	<b>Sq. Ft. Coverage</b>	<b>Dial Setting Full Rate</b>	<b>Dial Setting Half Rate</b>	<b>Spread Width</b>
Blue Grass or Red Top	.5 lbs.	1,000	1.25		4
	1 lbs.	1,000	2.0		4
	2 lbs.	1,000	2.5		4
Park, Merion, Delta, or Kentucky Bluegrass	.5 lbs.	1,000	2.5		4
	1 lbs.	1,000	3.0		4
	2 lbs.	1,000	3.5		4
Hulled Bermuda	2 lbs.	1,000	2.75	2.25	6
	3 lbs.	1,000	3.0	2.5	6
	4 lbs.	1,000	3.25	2.75	6
Mixtures Including Coarse Seeds	2 lbs.	1,000	6.0		6
	4 lbs.	1,000	7.0		6
	6 lbs.	1,000	7.0		6
Rye Grasses or Tall Fescue	2 lbs.	1,000	6.0		6
	4 lbs.	1,000	7.0		6
	6 lbs.	1,000	7.75		6
Dichondra	4 oz.	1,000	1.9		8
	8 oz.	1,000	2.1		8
	12 oz.	1,000	2.5		8
Pensacola Bahia	4 lbs.	1,000	4.5	3.75	7
	5 lbs.	1,000	4.75	4.0	7
	6 lbs.	1,000	5.0	4.25	7

**THIS PAGE INTENTIONALLY LEFT BLANK**



## 1 YEAR LIMITED WARRANTY

This is warranted to the original purchaser only. Spyker will replace parts with defects in materials and workmanship, for a period of one year from the date of purchase.

For Spyker Spreaders—a Brinly-Hardy Company, products employing metal gear systems, pinion and bevel, these metal gears, only, not inclusive of any other parts or materials, are warranted for the life of the spreader, not to be used for replacement or repair past original purchase.

Spyker Spreaders will not be liable for any loss, damage or expense including, but not limited to, consequential or incidental damages, arising from the operation, condition or use of the item. The sole and exclusive remedy against Spyker Spreaders being the replacement of the defective parts. This warranty gives you specific legal rights, and you may also have other rights which vary from state to state.

**This express warranty, which is applicable only to the original purchase, is in lieu of and excludes all other warranties, whether expressed or implied by operation of law or otherwise, including any warranty of merchantability or fitness for particular purpose.**

**SPYKER SPREADERS**  
**Jeffersonville, IN 47130 USA**  
**Phone: 800.972.6130**